



Mobile Handwash Station

Mobile Handwash Station

Holds 18 gallons (68,1 liters) of freshwater and 20.5 gallons (77,6 liters) of wastewater.

Project _____
Item No. _____
Model No. _____
Quantity _____



Features & Benefits

- Self-contained unit stores freshwater and collects wastewater and needs no electricity or plumbing to operate.
- Freshwater tank holds 18 gallons (68,1 liters).
- Wastewater (gray water) tank holds 20.5 gallons (77,6 liters).
- Sink / wastewater tank is removeable.
- Unit weight (empty) is 53.6 lbs. (24,3 kg).
- Unit weight (full) is 224.7 lbs. (101,9 kg).
- Casters: two each 3" diameter (7,6 cm) with precision bearings.
- Sink height from the ground is 34" (86,3 cm) (ADA compliant).
- Fill the freshwater tank by removing the port hole on the back of the unit, using a standard garden hose and filling up to the Max Fill line.
- The freshwater tank can be drained using the drain plug on the lower left side.
- Drain the wastewater tank using the valve drain on the lower right side. You can attach a hose for hard to reach drains.
- Includes two automatic, touchless soap dispensers that require 4 AA batteries each to operate.
 - Each soap dispenser holds 23.7 oz (700 ml) of liquid hand soap. Do not use foaming soap or hand sanitizer in the soap dispensers.
- Paper towel dispenser holds standard multifold paper towels.
- Unit comes fully assembled.
- Personalization available to add custom graphics to the curved, lower front surface area.
- Available in 1 color: Charcoal Gray (615).
- Patent has been applied for.



Approvals



Information and specifications are subject to change without notice. Please confirm at time of order.

© Cambro Manufacturing Company 5801 Skylab Road, Huntington Beach, California 92647-2056, U.S.A.

Telephone 714 848 1555 Toll Free 800 854 7631 Customer Service 800 833 3003 Email: customerservice@cambro.com

Printed in USA. 10/21

Mobile Handwash Station

Mobile Handwash Station

Holds 18 gallons (68,1 liters) of freshwater and 20.5 gallons (77,6 liters) of wastewater.

Project _____
 Item No. _____
 Model No. _____
 Quantity _____

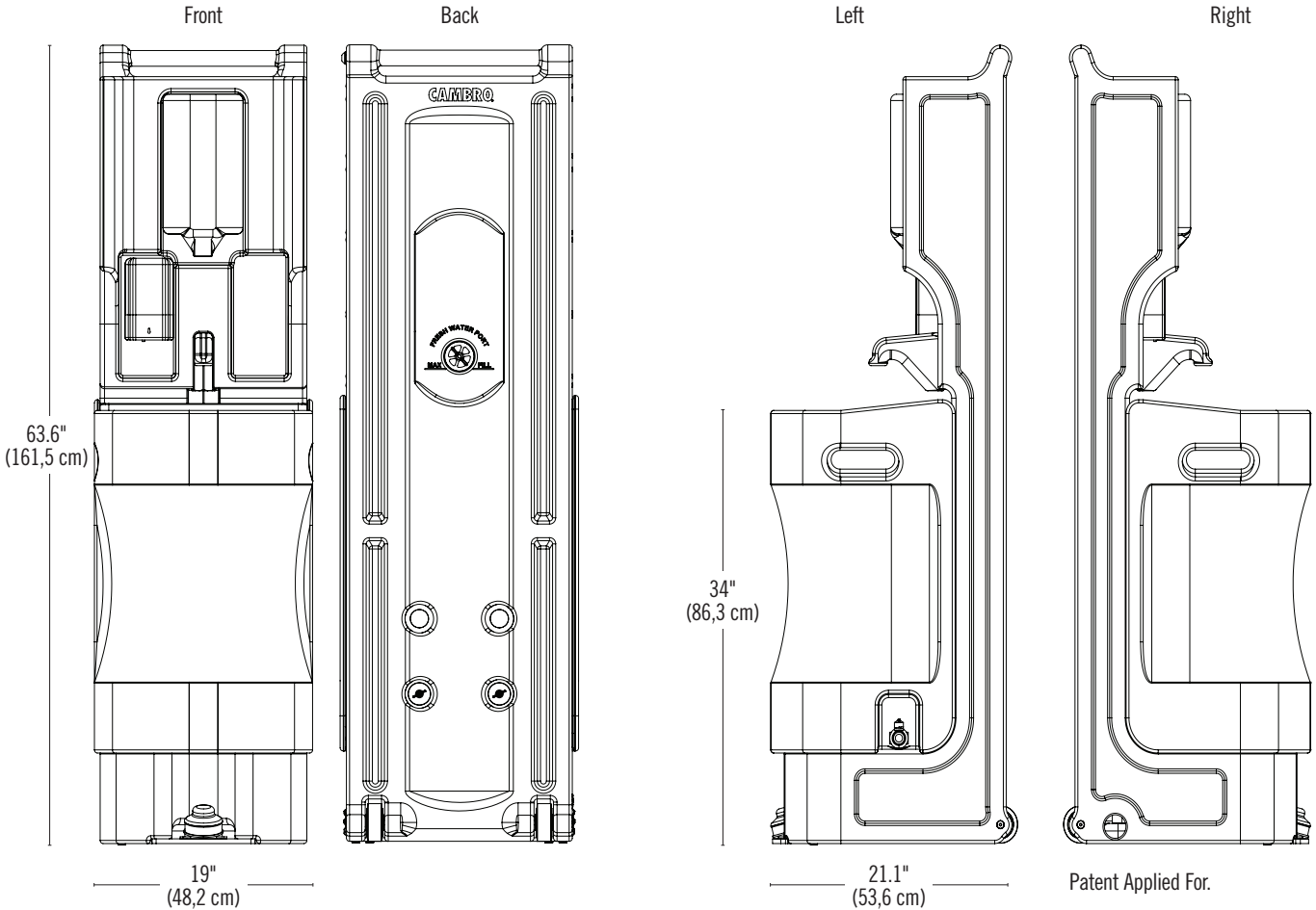

Specifications

Model	Dimensions (W x D x H)	Unit Weight
MHWS18	19" x 21.1" x 63.6" (48,2 x 53,6 x 161,5 cm)	53.6 lbs (24,1 kg)

Architect Specs

Body: Polyethylene.
 Soap Dispenser: ABS
 Paper Towel Dispenser: ABS
 Casters: Non-marking thermoplastic polyurethane wheel with precision bearings.

Approvals